

RENAULT
TRUCKS
DELIVER

RENAULT PREMIUM DISTRIBUTION

www.renault-trucks.co.uk



MAKING YOUR

DAY-TO-DAY BUSINESS EASIER

Boasting new, more powerful Euro 5 engines (270 hp to 460 hp) and offering optimised fuel consumption, new manual or automated **Optidriver+** gearboxes, as well as exceptional braking, Renault Premium Distribution brings you a blend of high performance and driving pleasure.





Renault Premium Distribution delivers excellent payloads, combined with remarkable onboard comfort, straightforward bodybuilding features and fittings that are highly appreciated by professionals. In addition, Renault Premium Distribution is supported by a host of solutions geared to boost your profitability. One such offering is Optifuel Solutions, a unique fuel optimisation tool from Renault Trucks.

2^{CAB}
ACCESS
STEPS

40
DIFFERENT
MODELS

MILE AFTER MILE

BOOST YOUR PRODUCTIVITY





REDUCE YOUR SERVICE AND MAINTENANCE COSTS

Reliable and powerful, the driveline fitted to the Renault Premium Distribution is engineered to require minimum maintenance:

- the first service inspection at 20,000 km is no longer needed
- longer oil change intervals
- maintenance-free suspension joints
- extended air cartridge life (120,000 km).

And there is also Start & Drive, the servicing and repair contract that gives you a clear picture of your maintenance costs through careful budget planning. Renault Trucks is fully committed to giving you maximum service with minimum downtime.

GET INTO HIGH GEAR

The robust driveline is designed to meet requirements specific to heavy distribution. The ease with which it handles both long trips and urban deliveries will allow you to increase average speeds.

TRANSPORT MORE

Renault Premium Distribution offers excellent payload capabilities so you can transport more freight, reduce the number of trips you make and increase profitability. The wide range of single and double-reduction drive axles means that you can find the right solution for your needs to boost your productivity gains every day.

OPTIDRIVER⁺:
60 KG
MORE
PAYLOAD

3%^{**}
LESS CONSUMPTION
WITH OPTIDRIVER⁺

*option

**on average, compared to a manual gearbox and on 11 l engines

ON ALL TYPES OF ROAD

EXPERIENCE NEW LEVELS OF PERFORMANCE

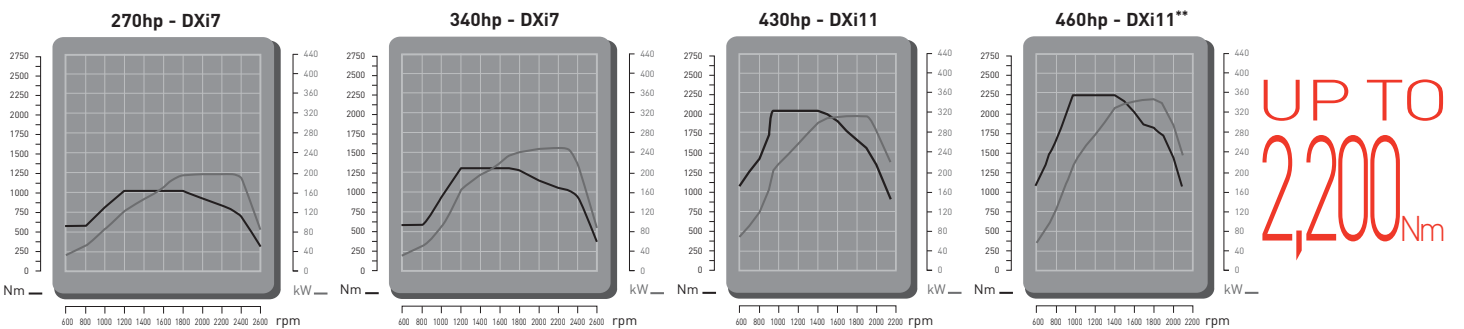

UP TO
2,200 Nm

310 and 380 hp versions also available, graphs not shown.

OPTIFUEL SOLUTIONS

With Optifuel Solutions, Renault Trucks gives you the most effective technologies and services to lower fuel consumption: optimised drivelines, **Optidriver+** automated gearbox, SCR technology, economic driver training, Optifuel Infomax.

NEW EURO 5 ENGINES FOR MAXIMUM POWER AND SAVINGS

Acclaimed for the high journey speeds it offers, the DXi11 Euro 5 engine now delivers even better performance with its new 380, 430 and 460 hp** power ratings coupled with class-leading fuel consumption figures. The DXi7 Euro 5 engine has also evolved and is now available in 270, 310 and 340 hp power ratings.

In order to comply with the EEV standard (Enhanced Environmentally Friendly Vehicle), Renault Trucks has developed a solution without a particulate filter*** that is simple and affordable to maintain.

POWER/TORQUE RATIOS ADAPTED TO MEDIUM AND LONG DISTANCE TRANSPORT

With its new power ratings offering increased torque (between 1,800 and 2,200 Nm for the DXi11, between 1,010 and 1,300 Nm for the DXi7), Renault Premium Distribution delivers the performance and fuel efficiency to better meet the needs of the distribution sector.

WITH **Optidriver+**, CONSUME LESS, DRIVE FURTHER

The new version of the **Optidriver+** automated gearbox offers superior performance in terms of gear change speed. It smoothes out variations in consumption and provides average savings of 3% against a manual gearbox. Integrating fewer moving mechanical parts than the equivalent manual gearbox, it offers a very significant reduction in maintenance and gives the clutch a much longer service life. With **Optidriver+** and the DXi11 engine, Renault Premium Distribution has the ideal driveline to enable higher sustained journey speeds.



UP TO
460_{hp}**



***Optidriver+** is an option on DXi11 engines or 6-speed Optitronic automated gearbox available as a customer adaptation on the DXi7 engine

**Renault Premium Distribution car transporter only

***available from September 2009 depending on engine size

FROM CITY TO CITY

ENJOY TOTAL COMFORT AS YOU MOVE AROUND

EASIER CAB ACCESS

To reduce the strain caused by repeatedly getting in and out of the vehicle, Renault Trucks devised the 'Access Concept' programme with doors opening 90°, non-slip access steps in line with the door, grab handles on either side of the door, stepwell lighting, adjustable seat and air-release steering wheel.

UNPARALLELED ERGONOMICS TO ENHANCE WELL-BEING

Renault Premium Distribution has an ergonomically designed dashboard that allows you to read all critical driver control information at a glance: enhanced digital display, indicator lamps, gauges and switches. Controls are within easy reach, storage compartments are easily accessible and the driving position is excellent.

DOORS
OPEN
90°

PRACTICAL, FUNCTIONAL FEATURES

Cab functions are very practical in design and comfortable to use. Whatever model you choose, the optimal space arrangement integrates an array of features as well as large storage compartments. A host of optional equipment makes life onboard a pleasure: time-delay lighting, 12 V and 24 V sockets, television stand, heated seats, etc.

A WIDE CHOICE OF CABS TO BE AT EASE ON THE ROAD

Renault Premium Distribution offers three different cab lengths (Day, Global, Sleeper) with the Sleeper cab specially designed to spend several nights on the road in superior comfort. There is also a choice of three roof heights. The cabs are fitted out in new interior trim designs with dirt-resistant fabric and colours.

EXCEPTIONAL TURNING RADIUS

With a compact cab, a short forward overhang (1,420 mm) and short wheelbases, Renault Premium Distribution is the perfect choice for negotiating urban traffic conditions. It is highly manoeuvrable as a result of its combined turning radius/short forward overhang.





EXCEPTIONALLY POWERFUL CENTRALISED BRAKING

The different braking systems (service brakes, engine brake and retarders) are coupled to the Electronic Braking System which adjusts the braking pressure applied to each wheel to match surface adhesion conditions. This means that Renault Premium Distribution always has 100% of its braking capabilities at its disposal. This centralised braking system is one of the best on the market and provides deceleration figures of 7 m/s^2 , better than current regulatory requirements.

GREAT VISIBILITY TO BRING EVERYTHING IN FOCUS

Renault Premium Distribution has a clear panoramic windscreen and wide windows that give an excellent view of the road ahead and its surroundings. The independent rear view mirrors, the main mirror and wide-angle mirror with vibration-free arms, as well as the front view mirror, all help to eliminate blind spots and ensure optimal visibility to both front and rear. These vision enhancement features can be complemented by the 'vision' door, with its glazed lower section designed to make manoeuvring easier, as well as a rear side window on the passenger side* and a rear window.



DECELERATION OF
7 m/s^2

500 kW
BRAKING
POWER**

*available on Global cab only
**with Optidriver+ and the VOITH retarder

FOR YOUR BUSINESS NEEDS

GET A CUSTOMISED TRUCK



A POWERFUL SOLUTION FOR YOUR NEEDS

Engineered as a heavy distribution specialist, Renault Premium Distribution presents exceptional features in a comprehensive range of vehicles ready to be adapted to your needs: industrial on-demand consignments, express delivery and controlled temperature transport, tanker transport, refuse collection, sewerage and drainage or car transporter. Excellent materials and superior build quality ensure that your investment lasts a very long time, and this is further enhanced by the use of cathodic treatment for corrosion protection, as well as a highly secure electric and electronic architecture.

SMOOTH, EASY BODYBUILDING

With wheelbases in 200 mm increments, pre-drilled and stamped side members and body fixing brackets, the Renault Premium Distribution chassis is optimised to make bodybuilding easier and more efficient.

Renault Trucks has developed a special electronic box for bodybuilders that allows easy, safe connection between body and vehicle electronics.



40 COMBINATIONS OFFERING TRUE CUSTOMISATION

The range of possibilities offered by Renault Trucks allows you to configure the Renault Premium Distribution that is right for your needs: tractors and rigids from 18 to 26 t GVW (4x2 and 6x2); 14 different wheelbases on the rigids, three on the tractors; a third axle, in steering and non-steering versions; a wide choice of power ratings (270 to 460 hp); a choice of three cabs and three roof heights; single and double-reduction drive axles; different trailer coupling heights; air or mechanical suspension.

For very specific needs, other models are available for special customer configurations such as the 6x2/4 rigid with rear-steering tag axle, for haulage, construction or road maintenance.

14 WHEELBASES AVAILABLE
FACTORY OPTIMISED CHASSIS



CABS

A flexible cab offering:

- **Day cab** (1,600 mm) practical, designed for maximum volume rigids
- **Global cab** (2,000 mm) the ideal blend of functionality and comfort. It is available in different styling trims: Global Standard - Global Relax - Global Night - Global Utility
- **Sleeper cab** (2,200 mm) spacious and comfortable and designed for long distance trips. Available with double bunk.

3 trim levels are on offer:

- **Authentique**
- **Alliance**
- **Privilege.**

ENGINES

DXi7 Euro 5

198 kW (270 hp) at 2,300 rpm - 1,010 Nm from 1,200 to 1,800 rpm
 228 kW (310 hp) at 2,300 rpm - 1,150 Nm from 1,200 to 1,800 rpm
 250 kW (340 hp) at 2,300 rpm - 1,300 Nm from 1,200 to 1,700 rpm

DXi11 Euro 5

280 kW (380 hp) at 1,800 rpm - 1,800 Nm from 950 to 1,400 rpm
 316 kW (430 hp) at 1,800 rpm - 2,040 Nm from 950 to 1,400 rpm
 338 kW (460 hp*) at 1,800 rpm - 2,200 Nm from 950 to 1,400 rpm

Renault Trucks has chosen the SCR (Selective Catalytic Reduction) post-treatment system to comply with the Euro 5 standard. This consists of several elements:

- AdBlue tank
- AdBlue dosing module
- Silencer enabling NOx catalysis to take place
- AdBlue injector in the exhaust
- Sensors ensuring the entire system is operating normally (detecting NOx, AdBlue levels and temperatures).

*car transporter only

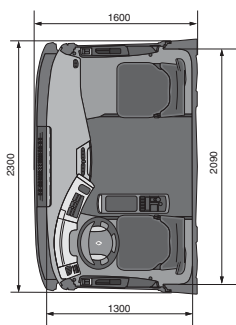

Day cab

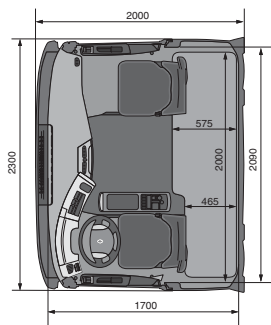

Global cab

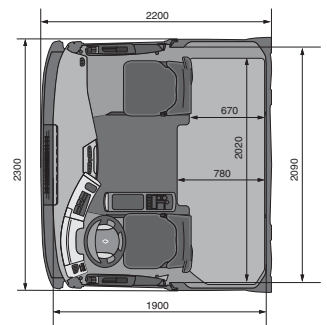

Sleeper cab

GEARBOXES

The manual, automatic and automated gearboxes provide an optimal combination of payload, fuel reduction and driving pleasure.

Designation		Ratios	Speeds	Super H
DXi7	6AS 1000*	6.75 - 0.77 (R 6.06)	6	
	6S 1000 TO	6.75-0.78 (R 8.63)	6	
	9S 1110 TO	9.49-0.75 (R 12.59)	9	•
	9S 1310 TO	9.49-0.75 (R 12.59)	9	•
	BVA 3200V	3.49-0.65 (R 5.36)	6	
DXi11	16S 1930 TD	16.47-1.0 (R 16.47)	16	•
	16S 2230 TD	16.47-1.0 (R 16.47)	16	•
	16S 1830 TO	13.8-0.84 (R 16.42)	16	•
	16S 2230 TO	13.8-0.84 (R 16.42)	16	•
	AT 2412D	14.94-1.0 (R 14.94)	12	
	AT 2612D	14.94-1.0 (R 14.94)	12	
	ATO 2612D	11.73-0.79 (R 14.84)	12	

All manual gearboxes (DXi7 and DXi11) come as standard with cable controls and the Servoshift air assist system to help reduce gear change time and effort. The DXi11 engine has the Driving Monitoring System (DMS), an expert economical driving aid system developed by Renault Trucks that is unique to the market. It gives continuous, real-time gear selection information so as to optimise consumption and performance.

*option, Optitronic automated gearbox, only available up to 21,500 kg gw and 310 hp

DXi11 fitted with the Optidriver+ gearbox

Probably the best automated gearbox on the market offering fast gear change speeds for the best mobility and consumption ratio. Automatic gear changing takes account of load, slope, engine mapping and driveline, as well as acceleration, retardation and braking commands.

DXi7 with automatic gearbox: Allison 3200 V

This 6-speed automatic gearbox, particularly suited to applications with frequent stop and starts, is now available on wheelbases from 3,500 m to 4,750 m.

The gearbox is programmed to eliminate gearchanging errors so as to protect the engine from overspeeding.

It allows precise, auto-adaptive gearchanging that takes into account vehicle load, driving conditions and wear.

The torque converter delivers smooth starts and better hill-start performance.

DRIVE AXLES

A broad range of single and double-reduction drive axles designed to best meet the different application needs and load requirements.

	P 13150 Single reduction	P 1391 Double reduction	P 13170/2 Single reduction	P 1361.7 Double reduction
DXi7	•	•	•	•
DXi11			•	•

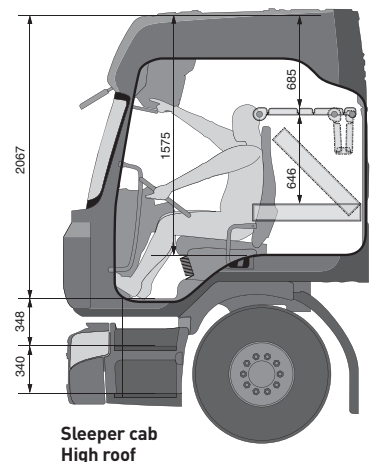
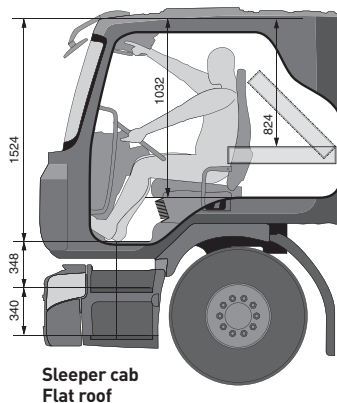
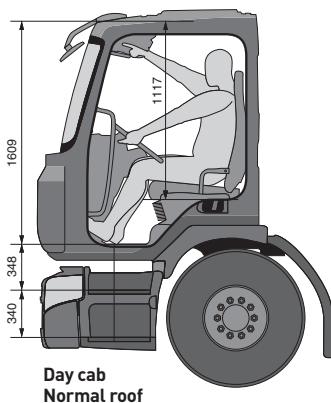

BRAKES

The Renault Premium Distribution range is fitted with the best brakes on the market for greater safety and added savings in consumption and maintenance:

- EBS 5 electronic control, available in 3 variants: EBS Basic, EBS Basic + and EBS Full (ESP)
- All-round disc brakes
- APM (Air Product Management) electronic air management system
- Comprehensive retarder offering: Telma electric (DXi7) and hydraulic intarder (9 and 16-speed manual gearboxes), Voith (**Optidriver+**), Allison (3200 V)
- Coupling of the different braking systems: service brakes, engine brake and retarders.

EBS Basic

- ABS
- Engine brake management
- Differential engagement management
- Traction test (semi-trailer)
- Emergency braking assistance
- Brake warning message
- Brake fail detection
- Brake balancing
- Coupling of retarders and service brakes.

EBS Basic +*

- EBS Basic functions
- ASR (traction control)
- Hill start assistance
- Brake pad wear balancing system.

EBS Full*

- EBS Basic + functions
- ESP (direction control and anti-roll program).

*option

SUSPENSION

Mechanical front suspension

Two mechanical suspension configurations offering standard ground clearance and optimised for front axle loads of 7.1 t (axle offset 125 mm), 8 t (axle offset 160 mm).

Increased ground clearance front axles available with axle offset 60 mm. Parabolic and asymmetric parabolic (short overhang) rear suspension. Rear air suspension with 250 mm travel, for greater stability and better ride comfort (loads to 13 t).

Front air suspension with 250 mm travel** for better height management and constant attitude control. Three configurations for loads up to 8 t: standard, lowered, and lowered for high volumes (GV).

WHEELBASES

Wheelbases mm	4 x 2 Rigid	6 x 2 Rigid	4 x 2 Tractor
3500	•	•	•
3700	•	•	•
3900	•	•	•
4100	•	•	
4300	•	•	
4500	•	•	
4750	•	•	
5000	•	•	
5250	•	•	
5500	•	•	
5800	•	•	
6100	•	•	
6450	•	•	
6800	•		

**not on car transporter





PROVIDING THE SUPPORT YOU NEED EVERY DAY

Renault Trucks Approved Parts: original parts quality

Approved Parts are designed and approved for Renault Trucks vehicles, the manufacturer is committed to maintaining its vehicles' original performance.

Renault Trucks 24/24

Whatever the time, day or place, Renault Trucks 24/24 roadside assistance is standing by to provide rapid breakdown assistance. A specially assigned contact will coordinate your assistance operation from beginning to end.

TAKE CONTROL OF YOUR BUDGET AND YOUR ASSETS

Start & Drive repair and maintenance contracts

Your Renault Trucks approved repairer takes full charge of your vehicle's maintenance, offering a range of different options geared to your needs - ensuring you are able to benefit from maximum availability of your vehicle.

Expandys warranty extensions

Enjoy the benefits of genuine insurance covering your vehicle's most important elements, defined according to your annual estimated mileage, together with the length and extent of coverage required - providing you with the best possible solution for your business.

Truckplus

The joint Renault Trucks and dealer network brand for used vehicles. Your guarantee of a thoroughly professional approach to offering and selling trucks from all major manufacturers.

www.truckplus.co.uk

RENAULT TRUCKS FINANCIAL SERVICES FINANCE AND INSURANCE

Renault Trucks Financial Services is committed to providing you with:

- A dedicated contact person who will offer you a comprehensive and personalised vehicle, services, finance and insurance solution package.
- A finance decision in the shortest possible time, to get your vehicle operational quickly.

Get in touch with your Renault Trucks sales advisor to discuss a personalised solution.

MONITOR CONSUMPTION AND EFFICIENT VEHICLE USE

Optifuel Programme

Optifuel Programme is the global solution designed to reduce your company's fuel costs. Combining Optifuel Training and Optifuel Infomax, this programme is designed for instructors, driver trainers and fleet managers who can then, in turn, train other drivers.

Optifuel Infomax

Optifuel Infomax is the global solution for monitoring vehicle usage and raising awareness of economic driving practices. The instruction you receive and its intuitive interface helps you control your vehicle's fuel consumption and accurately identify ways of making further savings.

Optifuel Training

Take advantage of our specialised instructors' expertise in economic driving and learn how to fully exploit your vehicles' potential for making savings.



YOU CAN SAVE UP
TO 15% OF YOUR
ENTIRE FLEET'S
OPERATING
COSTS

Renault Trucks UK Ltd
Houghton Hall Business Park
Porz Avenue
Dunstable
Beds LU5 5FT
Tel. 0870 60 60 660

www.renault-trucks.co.uk



We recommend
Renault Trucks Oils



measurements and characteristics shown in this document are provided for information purposes only. The manufacturer reserves the right to modify them without prior notice in the interests of improving its products so that they meet customer needs more closely.
PUBLISCI/CACHEMIRE Ref: 50 21 026 599 - Qty 1 500 copies - Renault Trucks SAS with a capital of 50 000 000 € - 954 506 077 RCS Lyon - Imprimerie Brailly 69564 Saint-Genis-Laval - 09/2009.